

Evolution Hybrid Press Brake Specifications

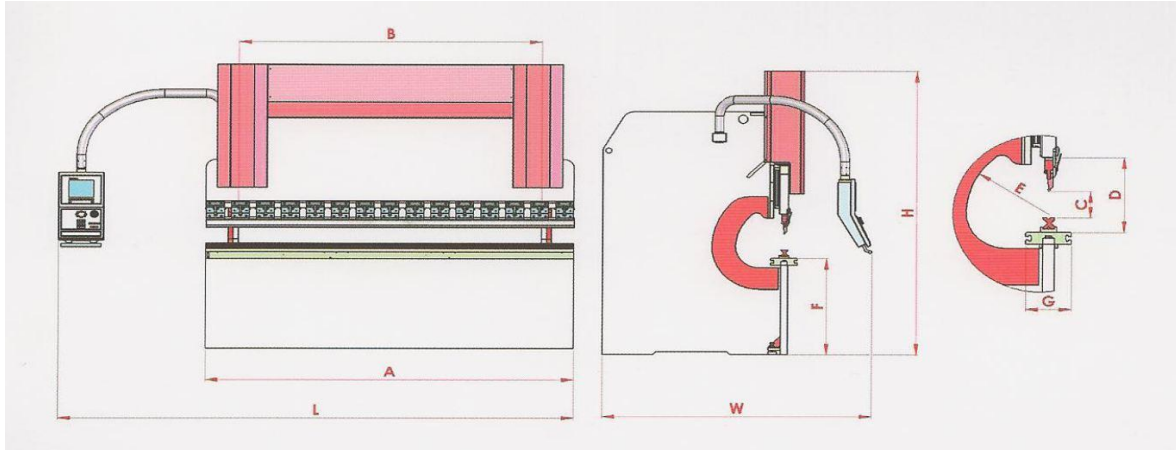

Bending length	122.0 inch
Max. power	135 ton
Max. bending capacity (42kg/mm2)	0.2 inch
Axis number of machine	Y1, Y2, X, R
Free down speed	7.9 inch/s
Bending speed	0.5 inch/s
Return back speed	7.5 inch/s
Stroke (C) (Y1, Y2)	10.8 inch
Back gauge stroke (X axis)	31.5 inch
Back gauge stroke (R axis)	9.8 inch
Distance between housing (B)	102.4 inch
Crowning	Manual
Throat depth (E)	16.1 inch
Table height (F)	35.4 inch
Table width	3.5 inch
Daylight (D)	21.7 inch
Plant voltage	380 V
IP	54
Main motor	2 x 6.3 HP
Back gauge motors (X, R)	2 x 2.4 Nm
Plant temperature	0-50 °C
Max. noise	70 dB
Oil capacity	2 x 5.3 gallons
Max. pressure	265 bar
Length (L)	167.3 inch
Width (W)	80.7 inch
Height (H)	110.2 inch
Weight	19140 lbs