

SYNCHRONIZED HYDRAULIC PRESS BRAKE - CNC AP - SPECIFICATIONS

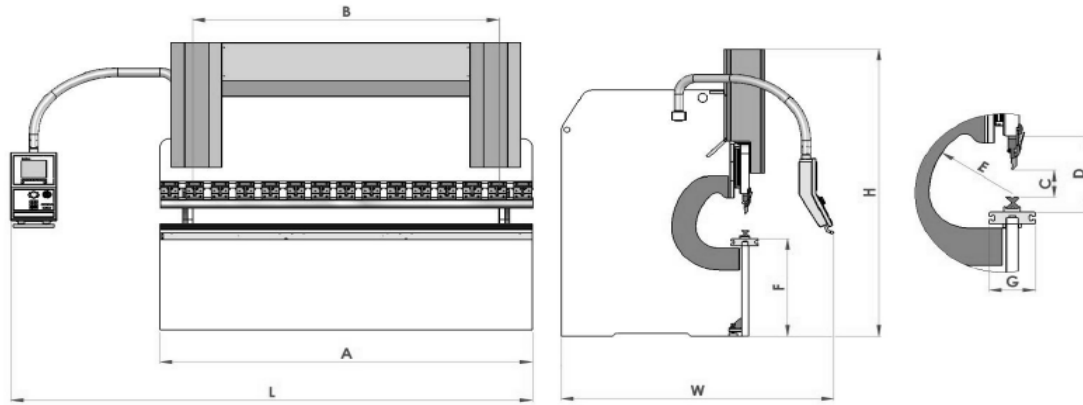

| TYPE | BENDING LENGTH | | BENDING POWER | | DISTANCE BETWEEN COLUMNS | | Y RAPID SPEED | Y WORKING SPEED * | Y RETURN SPEED | CROWNING | TRAVEL IN X AXIS | | SPEED OF X AXIS | | TRAVEL IN R AXIS | | SPEED OF R AXIS | | BACKGAUGE FINGER BLOCKS | NUMBER OF SHEET SUPPORT (Sliding front arms) | OIL CAPACITY | MOTOR POWER | STROKE | DAYLIGHT | THROAT DEPTH | TABLE HEIGHT | TABLE WIDTH | LENGTH | HEIGHT | WIDTH | WEIGHT | OPTIONAL | | | | | | | | | | |
|--------------------|----------------|------|---------------|----|--------------------------|--------|---------------|-------------------|----------------|----------|------------------|--------|-----------------|--------|------------------|--------|-----------------|----|-------------------------|--|--------------|-------------|--------|----------|--------------|--------------|-------------|--------|--------|-------|--------|----------|------|------|------|------|------|------|-----|----------------------------|----------------------------|----------------------------|
| | A | B | TON | HP | Inch | Inch/s | | | | | Inch | Inch/s | Inch | Inch/s | Amount | Amount | Gallon | HP | | | | | | | | | | | | | | Inch | Inch | Inch | Inch | Inch | Inch | Inch | lbs | SPEED OF TRAVEL X1.X2 AXIS | SPEED OF TRAVEL R1.R2 AXIS | SPEED OF TRAVEL Z1.Z2 AXIS |
| | Inch | Inch | Ton | HP | Inch | Inch/s | | | | | Inch | Inch/s | Inch | Inch/s | Amount | Amount | Gallon | HP | | | | | | | | | | | | | | Inch | Inch | Inch | Inch | Inch | Inch | Inch | lbs | Inch/s | Inch/s | Inch/s |
| CNC AP 1270 - 40 | 50 | 40 | 41 | 6 | 0.7 | 7 | - | 20 | 20 | 10 | 14 | 2 | 2 | 21 | 7 | 6.7 | 15 | 14 | 33 | 4 | 85 | 91 | 65 | 7040 | 20 | 14 | 39 | | | | | | | | | | | | | | | |
| CNC AP 1270 - 60 | 50 | 60 | 39 | 8 | 0.6 | 6 | - | 20 | 20 | 10 | 14 | 2 | 2 | 40 | 10 | 10.8 | 21 | 16 | 35 | 4 | 89 | 108 | 77 | 9460 | 20 | 14 | 39 | | | | | | | | | | | | | | | |
| CNC AP 2100 - 40 | 83 | 40 | 67 | 6 | 0.7 | 7 | Manuel | 20 | 20 | 10 | 14 | 2 | 2 | 21 | 7 | 6.7 | 15 | 14 | 33 | 4 | 114 | 91 | 65 | 9020 | 20 | 14 | 39 | | | | | | | | | | | | | | | |
| CNC AP 2100 - 60 | 83 | 60 | 67 | 8 | 0.6 | 6 | Manuel | 20 | 20 | 10 | 14 | 2 | 2 | 40 | 10 | 10.8 | 21 | 16 | 35 | 4 | 128 | 108 | 77 | 12760 | 20 | 14 | 39 | | | | | | | | | | | | | | | |
| CNC AP 2600 - 60 | 102 | 60 | 87 | 8 | 0.6 | 6 | Manuel | 20 | 20 | 10 | 14 | 2 | 2 | 40 | 10 | 10.8 | 21 | 16 | 35 | 4 | 148 | 108 | 77 | 13640 | 20 | 14 | 39 | | | | | | | | | | | | | | | |
| CNC AP 2600 - 100 | 102 | 100 | 87 | 8 | 0.5 | 8 | Manuel | 31 | 20 | 10 | 14 | 2 | 2 | 53 | 15 | 10.8 | 21 | 16 | 35 | 4 | 148 | 110 | 77 | 15400 | 20 | 14 | 39 | | | | | | | | | | | | | | | |
| CNC AP 2600 - 135 | 102 | 135 | 87 | 6 | 0.5 | 7 | Manuel | 31 | 20 | 10 | 14 | 2 | 2 | 79 | 20 | 10.8 | 22 | 16 | 35 | 4 | 148 | 110 | 81 | 18480 | 20 | 14 | 39 | | | | | | | | | | | | | | | |
| CNC AP 3100 - 100 | 122 | 100 | 102 | 8 | 0.5 | 8 | Manuel | 31 | 20 | 10 | 14 | 2 | 2 | 53 | 15 | 10.8 | 21 | 16 | 35 | 4 | 167 | 110 | 77 | 16720 | 20 | 14 | 39 | | | | | | | | | | | | | | | |
| CNC AP 3100 - 135 | 122 | 135 | 102 | 8 | 0.5 | 7 | Manuel | 31 | 20 | 10 | 14 | 2 | 2 | 79 | 20 | 10.8 | 22 | 16 | 35 | 4 | 167 | 110 | 81 | 19360 | 20 | 14 | 39 | | | | | | | | | | | | | | | |
| CNC AP 3100 - 175 | 122 | 175 | 102 | 7 | 0.5 | 7 | Manuel | 31 | 20 | 10 | 14 | 2 | 2 | 79 | 20 | 10.8 | 22 | 16 | 35 | 4 | 167 | 110 | 85 | 21120 | 20 | 14 | 39 | | | | | | | | | | | | | | | |
| CNC AP 3100 - 220 | 122 | 220 | 102 | 7 | 0.4 | 7 | Manuel | 31 | 20 | 10 | 14 | 2 | 2 | 79 | 25 | 10.8 | 22 | 16 | 35 | 8 | 179 | 112 | 89 | 25740 | 20 | 14 | 39 | | | | | | | | | | | | | | | |
| CNC AP 3100 - 260 | 122 | 260 | 102 | 6 | 0.4 | 5 | Manuel | 31 | 20 | 10 | 14 | 2 | 2 | 79 | 30 | 10.8 | 22 | 16 | 35 | 9 | 179 | 114 | 93 | 33440 | 20 | 14 | 39 | | | | | | | | | | | | | | | |
| CNC AP 3100 - 320 | 122 | 320 | 102 | 6 | 0.4 | 6 | Manuel | 31 | 20 | 10 | 14 | 2 | 2 | 106 | 40 | 14.8 | 26 | 16 | 35 | 9 | 179 | 114 | 96 | 38500 | 20 | 14 | 39 | | | | | | | | | | | | | | | |
| CNC AP 3100 - 400 | 122 | 400 | 100 | 4 | 0.3 | 5 | Motorized | 31 | 20 | 10 | 14 | 2 | 2 | 106 | 40 | 14.8 | 26 | 20 | 35 | 9 | 179 | 114 | 104 | 47300 | 20 | 14 | 39 | | | | | | | | | | | | | | | |
| CNC AP 3100 - 500 | 122 | 500 | 96 | 3 | 0.3 | 3 | Motorized | 31 | 20 | 10 | 14 | 2 | 2 | 132 | 40 | 14.8 | 27 | 20 | 41 | 9 | 193 | 114 | 104 | 59840 | 20 | 14 | 39 | | | | | | | | | | | | | | | |
| CNC AP 3760 - 175 | 148 | 175 | 128 | 7 | 0.5 | 7 | Manuel | 31 | 20 | 10 | 14 | 2 | 2 | 79 | 20 | 10.8 | 22 | 16 | 35 | 4 | 193 | 114 | 85 | 24420 | 20 | 14 | 39 | | | | | | | | | | | | | | | |
| CNC AP 3760 - 220 | 148 | 220 | 128 | 7 | 0.4 | 7 | Manuel | 31 | 20 | 10 | 14 | 2 | 2 | 79 | 25 | 10.8 | 22 | 16 | 35 | 6 | 201 | 114 | 89 | 28160 | 20 | 14 | 39 | | | | | | | | | | | | | | | |
| CNC AP 3760 - 320 | 148 | 320 | 128 | 6 | 0.4 | 6 | Manuel | 31 | 20 | 10 | 14 | 2 | 2 | 106 | 40 | 14.8 | 26 | 16 | 35 | 9 | 201 | 114 | 96 | 45760 | 20 | 14 | 39 | | | | | | | | | | | | | | | |
| CNC AP 4100 - 135 | 161 | 135 | 142 | 8 | 0.5 | 7 | Manuel | 31 | 20 | 10 | 14 | 2 | 2 | 79 | 20 | 10.8 | 22 | 16 | 35 | 4 | 201 | 114 | 83 | 23760 | 20 | 14 | 39 | | | | | | | | | | | | | | | |
| CNC AP 4100 - 175 | 161 | 175 | 142 | 7 | 0.5 | 7 | Manuel | 31 | 20 | 10 | 14 | 2 | 2 | 79 | 20 | 10.8 | 22 | 16 | 35 | 4 | 201 | 114 | 85 | 26620 | 20 | 14 | 39 | | | | | | | | | | | | | | | |
| CNC AP 4100 - 220 | 161 | 220 | 142 | 7 | 0.4 | 7 | Manuel | 31 | 20 | 10 | 14 | 2 | 2 | 79 | 25 | 10.8 | 22 | 16 | 35 | 8 | 203 | 114 | 89 | 30800 | 20 | 14 | 39 | | | | | | | | | | | | | | | |
| CNC AP 4100 - 260 | 161 | 260 | 142 | 6 | 0.4 | 5 | Manuel | 31 | 20 | 10 | 14 | 2 | 2 | 79 | 30 | 10.8 | 22 | 16 | 35 | 8 | 203 | 114 | 93 | 37180 | 20 | 14 | 39 | | | | | | | | | | | | | | | |
| CNC AP 4100 - 320 | 161 | 320 | 142 | 6 | 0.4 | 6 | Manuel | 31 | 20 | 10 | 14 | 2 | 2 | 106 | 40 | 14.8 | 26 | 16 | 35 | 9 | 211 | 114 | 96 | 49720 | 20 | 14 | 39 | | | | | | | | | | | | | | | |
| CNC AP 4100 - 400 | 161 | 400 | 140 | 4 | 0.3 | 5 | Motorized | 31 | 20 | 10 | 14 | 2 | 2 | 106 | 40 | 14.8 | 26 | 20 | 35 | 9 | 215 | 114 | 104 | 59400 | 20 | 14 | 39 | | | | | | | | | | | | | | | |
| CNC AP 4100 - 500 | 161 | 500 | 134 | 3 | 0.3 | 3 | Motorized | 31 | 20 | 10 | 14 | 2 | 2 | 132 | 40 | 14.8 | 27 | 20 | 43 | 9 | 215 | 114 | 104 | 71500 | 20 | 14 | 39 | | | | | | | | | | | | | | | |
| CNC AP 4100 - 600 | 161 | 600 | 134 | 3 | 0.3 | 3 | Motorized | 31 | 20 | 10 | 14 | 2 | 2 | 132 | 50 | 14.8 | 27 | 20 | 35 | 9 | 232 | 114 | 104 | 83600 | 20 | 14 | 39 | | | | | | | | | | | | | | | |
| CNC AP 4100 - 1250 | 161 | 1250 | 118 | 3 | 0.2 | 3 | Motorized | 39 | 20 | 10 | 14 | 2 | 2 | 317 | 74 | 20.1 | 39 | 24 | 31 | 17 | 232 | 114 | 130 | 189200 | 20 | 14 | 39 | | | | | | | | | | | | | | | |
| CNC AP 4100 - 1500 | 161 | 1500 | 114 | 3 | 0.2 | 3 | Motorized | 39 | 20 | 10 | 14 | 2 | 2 | 396 | 101 | 24.0 | 43 | 24 | 31 | 19 | 232 | 114 | 146 | 217800 | 20 | 14 | 39 | | | | | | | | | | | | | | | |
| CNC AP 4270 - 135 | 168 | 135 | 149 | 8 | 0.5 | 7 | Manuel | 31 | 20 | 10 | 14 | 2 | 2 | 79 | 20 | 10.8 | 22 | 16 | 35 | 4 | 208 | 114 | 85 | 24420 | 20 | 14 | 39 | | | | | | | | | | | | | | | |
| CNC AP 4270 - 220 | 168 | 220 | 149 | 7 | 0.4 | 7 | Manuel | 31 | 20 | 10 | 14 | 2 | 2 | 79 | 25 | 10.8 | 22 | 16 | 35 | 6 | 209 | 114 | 89 | 32560 | 20 | 14 | 39 | | | | | | | | | | | | | | | |
| CNC AP 4270 - 400 | 168 | 400 | 149 | 4 | 0.3 | 5 | Motorized | 31 | 20 | 10 | 14 | 2 | 2 | 106 | 40 | 14.8 | 26 | 20 | 35 | 9 | 220 | 114 | 104 | 60060 | 20 | 14 | 39 | | | | | | | | | | | | | | | |
| CNC AP 4270 - 600 | 168 | 600 | 142 | 3 | 0.3 | 3 | Motorized | 31 | 20 | 10 | 14 | 2 | 2 | 132 | 50 | 14.8 | 27 | 20 | 35 | 9 | 240 | 114 | 104 | 87120 | 20 | 14 | 39 | | | | | | | | | | | | | | | |
| CNC AP 6100 - 220 | 240 | 220 | 201 | 5 | 0.4 | 5 | Motorized | 31 | 20 | 10 | 14 | 4 | 4 | 79 | 25 | 10.8 | 22 | 16 | 43 | 6 | 295 | 114 | 93 | 57200 | 20 | 14 | 39 | | | | | | | | | | | | | | | |
| CNC AP 6100 - 320 | 240 | 320 | 201 | 4 | 0.4 | 3 | Motorized | 31 | 20 | 10 | 14 | 4 | 4 | 106 | 40 | 14.8 | 26 | 16 | 43 | 6 | 295 | 114 | 96 | 74800 | 20 | 14 | 39 | | | | | | | | | | | | | | | |
| CNC AP 6100 - 400 | 240 | 400 | 201 | 4 | 0.3 | 3 | Motorized | 31 | 20 | 10 | 14 | 4 | 4 | 106 | 40 | 14.8 | 26 | 20 | 43 | 8 | 301 | 114 | 104 | 89320 | 20 | 14 | 39 | | | | | | | | | | | | | | | |
| CNC AP 6100 - 500 | 240 | 500 | 201 | 3 | 0.3 | 3 | Motorized | 31 | 20 | 10 | 14 | 4 | 4 | 132 | 40 | 14.8 | 27 | 20 | 35 | 9 | 311 | 114 | 104 | 96800 | 20 | 14 | 39 | | | | | | | | | | | | | | | |
| CNC AP 6100 - 600 | 240 | 600 | 201 | 3 | 0.3 | 3 | Motorized | 31 | 20 | 10 | 14 | 4 | 4 | 132 | 50 | 14.8 | 27 | 20 | 35 | 9 | 311 | 114 | 104 | 121000 | 20 | 14 | 39 | | | | | | | | | | | | | | | |
| CNC AP 6100 - 800 | 240 | 800 | 201 | 3 | 0.2 | 3 | Motorized | 39 | 20 | 10 | 14 | 4 | 4 | 211 | 50 | 16.1 | 28 | 24 | 35 | 9 | 311 | 114 | 120 | 138600 | 20 | 14 | 39 | | | | | | | | | | | | | | | |
| CNC AP 6100 - 1000 | 240 | 1000 | 201 | 3 | 0.2 | 2 | Motorized | 39 | 20 | 10 | 14 | 4 | 4 | 26 | 60 | 20.1 | 35 | 24 | 31 | 13 | 311 | 114 | 128 | 167200 | 20 | 14 | 39 | | | | | | | | | | | | | | | |
| CNC AP 6100 - 1250 | 240 | 1250 | 197 | 3 | 0.2 | 2 | Motorized | 39 | 20 | 10 | 14 | 4 | 4 | 317 | 74 | 20.1 | 39 | 24 | 31 | 15 | 311 | 114 | 134 | 228800 | 20 | 14 | 39 | | | | | | | | | | | | | | | |
| CNC AP 6100 - 1500 | 240 | 1500 | 193 | 3 | 0.2 | 2 | Motorized | 39 | 20 | 10 | 14 | 4 | 4 | 396 | 101 | 24.0 | 43 | 24 | 31 | 16 | 311 | 114 | 146 | 264000 | 20 | 14 | 39 | | | | | | | | | | | | | | | |
| CNC AP 7100 - 400 | 280 | 400 | 240 | 4 | 0.3 | 3 | Motorized | 31 | 20 | 10 | 14 | 4 | 4 | 106 | 40 | 14.8 | 26 | 20 | 35 | 8 | 335 | 114 | 104 | 105600 | 20 | 14 | 39 | | | | | | | | | | | | | | | |
| CNC AP 7100 - 500 | 280 | 500 | 240 | 3 | 0.3 | 3 | Motorized | 31 | 20 | 10 | 14 | 4 | 4 | 132 | 40 | 14.8 | 27 | 20 | 35 | 9 | 335 | 114 | 104 | 116600 | 20 | 14 | 39 | | | | | | | | | | | | | | | |
| CNC AP 7100 - 600 | 280 | 600 | 240 | 3 | 0.3 | 3 | Motorized | 31 | 20 | 10 | 14 | 4 | 4 | 132 | 50 | 14.8 | 27 | 20 | 35 | 9 | 335 | 114 | 104 | 138600 | 20 | 14 | 39 | | | | | | | | | | | | | | | |
| CNC AP 7100 - 800 | 280 | 800 | 240 | 3 | 0.2 | 3 | Motorized | 39 | 20 | 10 | 14 | 4 | 4 | 211 | 50 | 16.1 | 28 | 24 | 35 | 9 | 335 | 114 | 120 | 156200 | 20 | 14 | 39 | | | | | | | | | | | | | | | |
| CNC AP 7100 - 1000 | 280 | 1000 | 240 | 3 | 0.2 | 2 | Motorized | 39 | 20 | 10 | 14 | 4 | 4 | 264 | 60 | 20.1 | 35 | 24 | 31 | 13 | 335 | 114 | 128 | 202400 | 20 | 14 | 39 | | | | | | | | | | | | | | | |
| CNC AP 7100 - 1250 | 280 | 1250 | 236 | 3 | 0.2 | 2 | Motorized | 39 | 20 | 10 | 14 | 4 | 4 | 317 | 74 | 20.1 | 39 | 24 | 31 | 14 | 335 | 114 | 134 | 268400 | 20 | 14 | 39 | | | | | | | | | | | | | | | |
| CNC AP 7100 - 1500 | 280 | 1500 | 232 | 3 | 0.2 | 2 | Motorized | 39 | 20 | 10 | 14 | 4 | 4 | 396 | 101 | 24.0 | 43 | 24 | 31 | 16 | 335 | 114 | 146 | 308000 | 20 | 14 | 39 | | | | | | | | | | | | | | | |
| CNC AP 8100 - 320 | 319 | 320 | 280 | 4 | 0.4 | 3 | Motorized | 31 | 20 | 10 | 14 | 4 | 4 | 106 | 40 | 14.8 | 26 | 16 | 35 | 6 | 374 | 114 | 98 | 107800 | 20 | 14 | 39 | | | | | | | | | | | | | | | |
| CNC AP 8100 - 400 | 319 | 400 | 280 | 4 | 0.3 | 3 | Motorized | 31 | 20 | 10 | 14 | 4 | 4 | 106 | 40 | 14.8 | 26 | 20 | 35 | 6 | 374 | 114 | 104 | 121000 | 20 | 14 | 39 | | | | | | | | | | | | | | | |
| CNC AP 8100 - 500 | 319 | 500 | 280 | 3 | 0.3 | 3 | Motorized | 31 | 20 | 10 | 14 | 4 | 4 | 132 | 40 | 14.8 | 27 | 20 | 35 | 9 | 378 | 114 | 104 | 138600 | 20 | 14 | 39 | | | | | | | | | | | | | | | |
| CNC AP 8100 - 600 | 319 | 600 | 280 | 3 | 0.3 | 3 | Motorized | 31 | 20 | 10 | 14 | 4 | 4 | 132 | 50 | 14.8 | 27 | 20 | 35 | 9 | 378 | 114 | 116 | 156200 | 20 | 14 | 39 | | | | | | | | | | | | | | | |
| CNC AP 8100 - 800 | 319 | 800 | 280 | 3 | 0.2 | 3 | Motorized | 39 | 20 | 10 | | | | | | | | | | | | | | | | | | | | | | | | | | | | | | | | |